

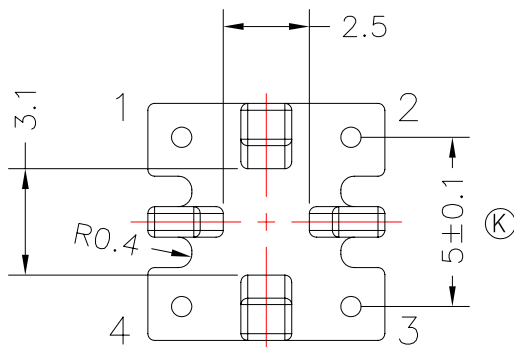

TRANSFORMER BOBBIN  
INDUSTRIAL CO.,LTD.

Tel : 86-769-88789999 Fax : 86-769-88789989  
http:// tbi-tw.com e-mail : tb6688@ms46.hinet.net

REVISIONS				
REV	SYM	DRAFTER	CHECKER	DATE
①		X.X.YUAN	G.F.YANG	07/03/15
②				
③				

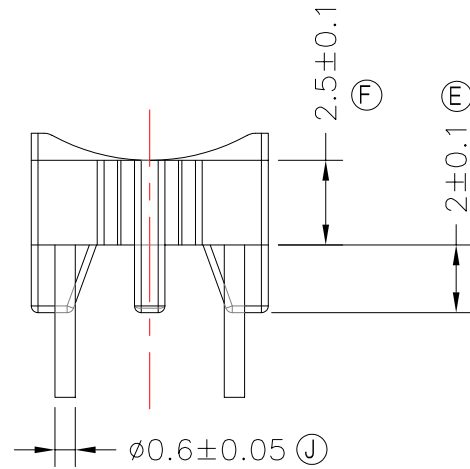
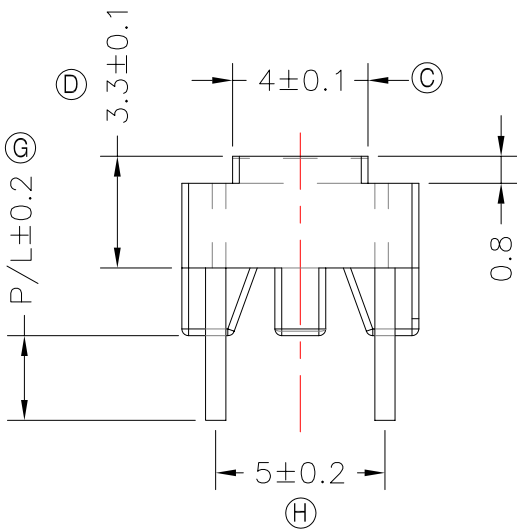
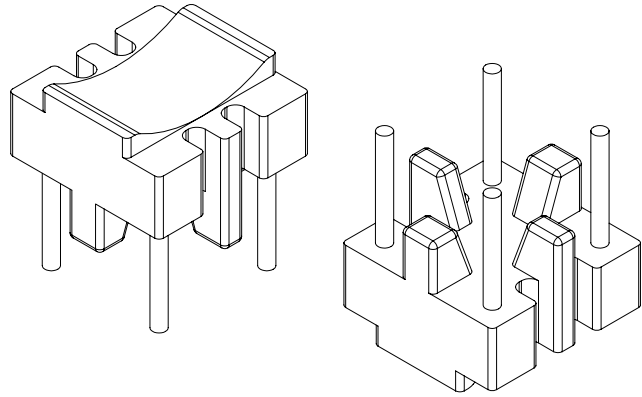
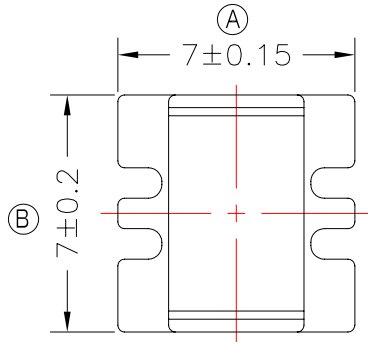

NOTE:

- 1.任意一點強度須2.5kg MIN;
- 2.耐壓4.0Kv /1.5mA 60S;
- 3.焊錫溫度:450°±10° 3SEC
- 4.焊錫前拉力:1.0KG MIN,焊錫後拉力:1.5KG MIN;

DWG NO.	B7X7-4P-TH-5.0-B-11				
PART NO.	MATERIAL (BOBBIN)	MATERIAL (TERMINAL)	TERMINAL (PLATING)	PIN ALLOCATION	NOTE
TBI-220-16021.1106	PM-9630	CP WIRE	Sn	ALL PIN P/L=3.4±0.2	H
TBI-220-16021.1116	PM-9630	CP WIRE	Sn	ALL PIN P/L=3.0±0.2	
TBI-220-16021.1126	PM-9630	CP WIRE	Sn	ALL PIN P/L=3.0±0.2	咬花外露:咬花寬度1.5±0.3, 深度0.05+0.02/-0.03
TBI-220-16021.1136	PM-9630	CP WIRE	Sn	ALL PIN P/L=3.4±0.2	咬花外露:咬花寬度1.5±0.3, 深度0.05+0.02/-0.03
	TOLERANCE: .X±0.15 .XX±0.10 .XXX±0.05			UNIT : m / m	SCALE 1 : 1
Finish:	1. PB wire Immersion Sn on terminal : Thickness:Sn plating,100,5 μm (200 μ inches) min,Base nickel 0.625 μm (25 μ inches) min. 2. CP wire Immersion Sn on terminal : Thickness:Sn plating,100,5 μm (200 μ inches) min. 3. Coplanarity deviation: 0.10 mm (0.004 inches )max.				REV 1